

--	--	--	--	--	--	--	--	--	--

**Sixth Semester B.E. Degree Examination, June/July 2016**  
**Mechatronics and Microprocessor**

Time: 3 hrs.

Max. Marks:100

**Note: Answer FIVE full questions, selecting  
at least TWO questions from each part.**

**PART - A**

- 1 a. What are the basic functions of control system? Mention the requirement of it in detail. (06 Marks)
- b. What are the benefits of mechatronics in industries? (06 Marks)
- c. Draw the structure of a programmable logic controller and mention the functions of each block. (08 Marks)
- 2 a. A potentiometer resistance transducer has a total winding resistance of  $8K\Omega$  and a maximum displacement range of 5cm. The power dissipation at maximum displacement is not to exceed 50 mW. Determine the output voltage of the transducer when the input displacement is 2cm. (06 Marks)
- b. What are position sensors? Explain the working of Hall effect sensors and mention the advantages of it. (08 Marks)
- c. Explain the operation of a linear variable differential transducer. (06 Marks)
- 3 a. Draw the switching arrangement of break before make and make before break. Mention disadvantages of mechanical switches. (06 Marks)
- b. What are solenoids? What are the parameters to be consider for selecting a solenoids for an application. (06 Marks)
- c. What is stepper motor and explain the working of a two stack stepper motor. (08 Marks)
- 4 a. Explain the operation of a optical isolator. (06 Marks)
- b. For the op-amp circuit shown in Fig.Q.4(b), find the output voltage. (04 Marks)

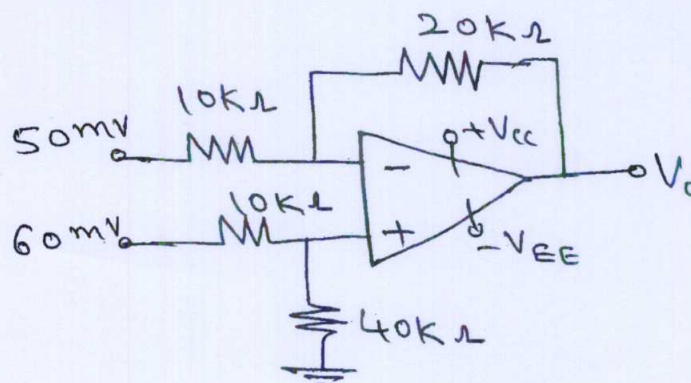

Fig.Q.4(b)

- c. Illustrate a data acquisition system. (07 Marks)
- d. What are the advantages of digital signal processing over analog signal processing? (03 Marks)

**PART – B**

- 5 a. Convert the following:
- $(ABC)_{16} = (\underline{\hspace{2cm}})_{10}$
  - $(204.2)_8 = (\underline{\hspace{2cm}})_{10}$
  - $(0.60)_{10} = (\underline{\hspace{2cm}})_2$
  - $(101010.101)_2 = (\underline{\hspace{2cm}})_{10}$ . (08 Marks)
- b. Write a note on overflow and underflow. (06 Marks)
- c. Simplify the Boolean expression and realize using basic gates  $Y = A(\overline{ABC} + A\overline{BC})$ . (06 Marks)
- 6 a. Define the following terms with respect to microprocessor:
- Fetch cycle
  - Accumulator
  - Interrupts
  - Stack pointer
  - Write cycle. (10 Marks)
- b. Draw the block diagram of a micro controller and mention the functions of each block. (10 Marks)
- 7 a. Explain the different types of addressing modes of INTEL 8085 microprocessor with example. (10 Marks)
- b. Write a program to find the largest of N binary numbers that are stored at consecutive data memory locations starting at X. (07 Marks)
- c. What is the function of logical group of instructions and mention few of it. (03 Marks)
- 8 a. Draw the block diagram of a control unit and explain it. (10 Marks)
- b. Draw and explain the timing diagram of read operation. (10 Marks)

\*\*\*\*\*